

MODEL 453P, 453S, 454P, 458P & 458PS SOLENOID VALVE INSTALLATION INSTRUCTIONS

LINE STRAINER:

A strainer, with an 80-mesh or finer screen, should be installed in the line ahead of the solenoid valve. This will assure tight seating and reliable closing action.

FLUIDS:

Valves are intended for water, air, light oil, and other noncorrosive fluids. They should **not** be used for gasoline and other hazardous or explosive fluids. Maximum fluid temperature is 200° F (93.3°C). Ambient temperature shall not exceed 120°F (48.8°C).

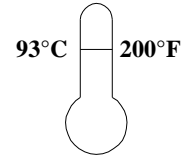

WARNING: NOT FOR USE WITH HAZARDOUS OR CORROSIVE OR EXPLOSIVE FLUIDS.

INSTALLATION:

DEMA valves may be installed in either horizontal or vertical lines and in any position other than with the coil lower than the body.

MODEL NO.	WATTS AC	VOLTS AC	AMPERES				D C		
			INRUSH		HOLDING		RATED WATTS	VOLTS	AMP.
			50 Hz	60Hz	50 Hz	60 Hz			
453P	15	24	3.7	3.0	1.6	1.2	18	12	1.5
453S		120	0.73	0.60	0.33	0.24		24	0.7
454P		208	0.41	0.35	0.19	0.14		32	0.6
458P		240	0.36	0.30	0.16	0.12		115	0.15
458PS									

VALVE MODEL	Cv	NPT (inches)	ORIFICE DIA. (inches)
453P, 453S	1.80	3/8	0.350
454P	3.70	1/2	0.500
458P, 458PS	11.10	1	0.939

PRESSURE DIFFERENTIAL:

10 PSI Min. (0.68 Bar) and 1,200 PSI Max. (81.6 Bar) *

* When using a DC coil derate the valve to 900 PSI for reliable operation.

SERVICING:

1. Failure to open.
 - a. No power, or low voltage.
 - b. Open circuit.
 - c. Burned-out coil (usually due to wrong voltage. See stamping opposite junction box).
 - d. Pressure differential too high (see M.O.P.D. on nameplate).
 - e. Moving parts jammed by dirt or damaged solenoid stainless steel tube.

2. Failure to close.
 - a. Coil is still energized.
 - b. Valve is installed backward.
 - c. Dirt is on valve seat or pilot seat.
 - d. Dirt is in piston ring or in groove (some models).
 - e. Moving parts jammed by dirt or damaged solenoid stainless steel tube.

**MODEL 453P, 453S, 454P, 458P & 458PS SOLENOID VALVE
INSTALLATION INSTRUCTIONS**

**HIGH PRESSURE SOLENOID VALVES
MODELS 453P, 453S, 454P, 458P, 458PS**

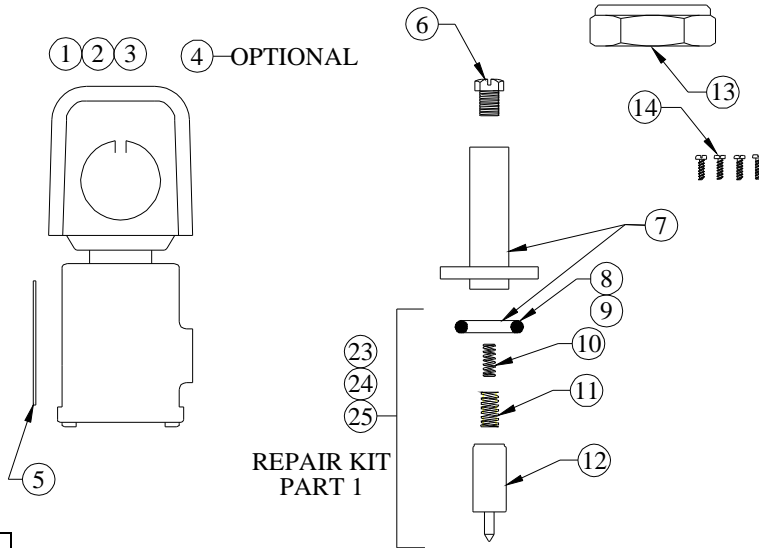

MODEL	PARTS USED
453P	Brass Bore (No SS Sleeve) SS Piston
453S	SS Sleeve SS Piston
454P	SS Sleeve Brass Piston
458P	SS Sleeve Brass Piston
458PS	SS Sleeve SS Piston

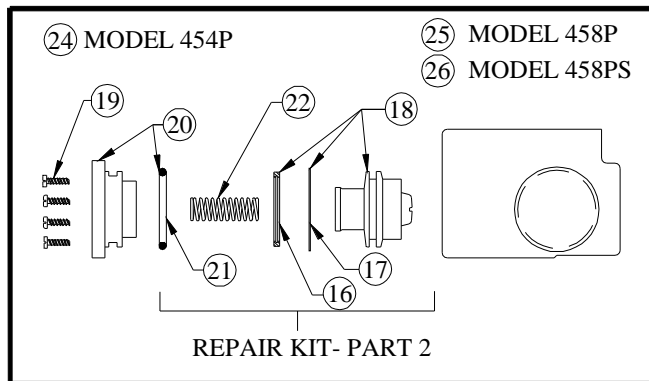
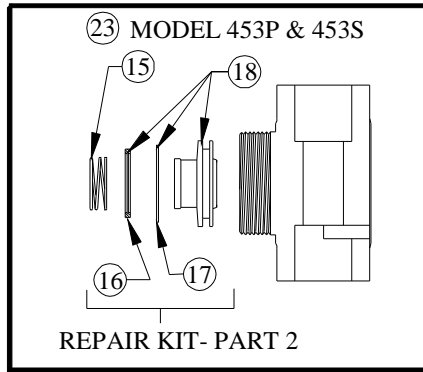

MODEL 453P, 453S, 454P, 458P & 458PS SOLENOID VALVE INSTALLATION INSTRUCTIONS

NO.	PART NO.	DESCRIPTION	VALVE MODEL NUMBER			
			453P/453S	454P	458P	458PS
1	41-9-2	Coil Assembly (Specify Voltage)	*	*	*	*
2	41-9C-2	(Optional) Coil Assembly With Conduit Boss (Specify Voltage)	*	*	*	*
3	41-9D-2	Din Coil (Specify Voltage)	*	*	*	*
4	41-77-100110	(Optional) Din Female Connector	*	*	*	*
5	41-13-6	Nameplate (Specify Model No.)	*	*	*	*
6	41-14-1	Top Plug Screw	*	*	*	*
7	41-7-22	Enclosing Tube With O-Ring			*	*
	41-7-23	Enclosing Tube With O-Ring		*		
	41-7-24	Enclosing Tube With O-Ring	*			
8	41-5-2	O-Ring, Buna-N (1 X 1 1/8 X 1/16)	*			
9	24-3	O-Ring, Buna-N (13/16 X 15/16 X 1/16)		*	*	*
10	41-1-6	Plunger Spring Return	*	*	*	*
11	41-1-7	Plunger Spring Kickoff	*	*	*	*
12	41-10-10	Plunger Assembly		*	*	*
	41-10-12	Plunger Assembly	*			
13	41-17-1	Enclosing Tube Locknut		*	*	*
	41-17-5	Enclosing Tube Locknut	*			
14	41-16-1	Enclosing Tube Screw (4 Req'd.)		*		
15	41-4-1	Closing Spring	*			
16	41-43-2	Piston Ring	*	*		
	X15195-1	Piston Ring (Std. # only, no DEMA #)			*	*
17	41-20-2	Backup Spring	*	*		
	41-20-6	Backup Spring			*	*
18	41-3-5	Piston Assy., SS With Ring & Backup Spring	*			
	41-3-6	Piston Assy., Brass With Ring & Backup Spring		*		
	41-3-8	Piston Assy., Brass With Ring & Backup Spring			*	
	41-3-9	Piston Assy., Brass With Ring & Backup Spring				*

**MODEL 453P, 453S, 454P, 458P & 458PS SOLENOID VALVE
INSTALLATION INSTRUCTIONS**

NO.	PART NO.	DESCRIPTRION	VALVE MODEL NUMBER			
			453P/453S	454P	458P	458PS
19	41-16-3	Piston Bore Lid Screw (4 Req'd.)		*		
	41-16-4	Piston Bore Lid Screw (4 Req'd.)			*	*
20	41-18-1	Piston Bore Lid With O-Ring		*		
	41-18-2	Piston Bore Lid With O-Ring			*	*
21	41-6-1	Piston Bore Lid O-Ring			*	*
	41-6-2	Piston Bore Lid O-Ring		*		
22	41-4-2	Closing Spring		*		
	41-4-3	Closing Spring			*	*
23	41-31	Repair Kit W/SS Piston (Models 453P & 453S)	*			
24	41-32	Repair Kit W/Brass Piston (Model 454P)		*		
25	41-33	Repair Kit W/Brass Piston (Model 458P)			*	
26	41-33-2	Repair Kit W/SS Piston (Model 458PS)				*

RETURNS: **NO MERCHANDISE MAY BE RETURNED FOR CREDIT WITHOUT DEMA'S WRITTEN PERMISSION. RETURN MERCHANDISE AUTHORIZATION NUMBER REQUIRED IN ADVANCE OF RETURN.**

WARRANTY: DEMA products are warranted against defective material and workmanship under normal use and service for one year from the date of manufacture. This limited warranty does not apply to any products which have a normal life shorter than one year or failure and damage caused by chemicals, corrosion, improper voltage supply, physical abuse, or misapplication. Rubber and synthetic rubber parts such as "o"-rings, diaphragms, squeeze tubing and gaskets are considered expendable and are not covered under warranty. This warranty is extended only to the original buyer of DEMA products. If products are altered or repaired without prior approval of DEMA, this warranty will be void.

Defective units or parts should be returned to the factory with transportation prepaid. If inspection shows them to be defective, they will be repaired or replaced without charge, F.O.B. factory. DEMA assumes no liability for damages. Return merchandise authorization number, to return units for repair or replacement, must be granted in advance of return.